

BELAZ-75581 mining dump truck with 90 tonnes payload capacity

It's designed for transportation of rock in severe mining conditions of deep mines,
at open pit mines on roads under various climatic operating conditions
(at ambient temperature from -50 to +50°C)



Engine

Model	CUMMINS QST 30-C
Diesel, four-stroke, with V-engine arrangement of cylinders, direct fuel injection, electronic control system, gas turbine supercharging and intermediate cooling of supercharging air.	
Meets the requirements for the release of toxic substances Tier2.	
Rated power at 1900 rpm, kW (hp)	783 (1050)
Maximum torque at 1300 rpm, N*m	4630
Number of cylinders	12
Cylinder displacement, l	30
Cylinder diameter, mm	140
Piston stroke, mm	165
Specific fuel consumption at rated power, g/kW*hr	199
Air is cleaned by three-stage filter with dry-type elements.	
Engine exhaust is routed through dump truck body.	
Circulating and pressurized lubrication system with «wet» sump.	
Single-loop fluid cooling system with forced circulation.	
Oil is cooled by oil-to-water heat exchanger.	
Fluid preheating system.	
Electric starting system.	
Electric system voltage, V	24

Transmission

AC drive with traction alternator, two traction motors, motor-in-wheel reduction units, adjustment and control devices.	
Maximum dump truck speed, km/h	60
Motor-in-wheel reduction unit ratio	30.36

Traction alternator	GST 700-8
Traction motor	TAD-9

Suspension

Conventional suspension for front and rear wheels with pneumohydraulic (nitrogen and oil) cylinders with inbuilt hydraulic shock absorber; two cylinders are on the front axle and two cylinders are on the rear axle.

Cylinder piston stroke, mm:

front	260
rear	210

Steering

Hydrostatic steering with steerable front wheels.

Steering angle, degree	38
Turning radius, m	11
Overall turning diameter, m	24

The steering meets ISO 5010 requirements.

Hydraulic system

Combined hydraulic system for body dumping gear, steering and brakes. Three-stage telescopic body lifting cylinders with one stage of double action. Variable-displacement axial-piston oil pump.

Body lifting time, s	21
Body lowering time, s	19
Maximum pressure in hydraulic system, MPa	18
Maximum pump delivery at 1900 rpm, dm ³ /min	474
Filtration degree, µm	10

Cab

Two-man two-door cab with air-sprung adjustable driver seat, additional trainee seat. The cab meets EN 474-1 and EN 474-6 requirements for in-cab noise, vibration, content of hazardous substances and dust. Driver's workplace meets ROPS safety requirements. In-cab noise level is not more than 80 dB(A).

Body

Welded bucket-type body with FOPS, ROPS, engine exhaust heating, device for mechanical fixing in raised position, rock-fenders and rock-ejectors.

Body capacity, m³:

struck	heaped 2:1
37.7	53.3
44.5	60.0
75.0	93.0
86.5	103.0

BELAZ 75581



WWW.BELAZ.BY

Brake system

Brake system meets international safety regulations and requirements of ISO 3450 and includes service, parking, auxiliary and emergency brakes.

Service brakes:

front wheels – dry single-disk brakes with two brake gears per disk and automatic gap adjustment;

rear wheels – dry single-disk brakes with one brake gear per disk and automatic gap adjustment.

Parking brakes:

Permanently closed brakes of rear wheels, spring drive and hydraulic control.

Auxiliary brakes:

Electrodynamic braking by traction motors in generator mode with forced cooling of brake resistors.

Emergency brakes:

Parking brake and operable circuit of service brakes.

Brake resistors

UVTR 2x600

Dissipated power, kW

1200

Special equipment

Remotely actuated fire extinguishing system (standard)

Starting preheater (standard, excepting tropicalized dump trucks)

Video observation system (standard)

Centralized automatic lubrication system (standard)

Telemetering tire-pressure monitoring system (standard)

High-voltage line approach attention device (standard)

Loading and fuel control system (standard)

Heating and conditioning unit (standard)

Body floor lining (optional)

Overall dimensions, mm

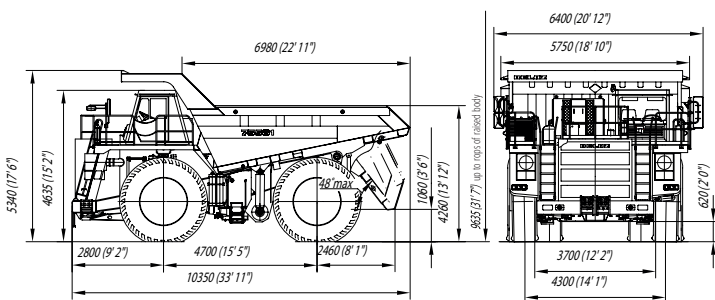

Overall dimensions are specified for basic configuration of the dump truck. The above specifications are subject to change without notice due to the continuous improvement of the vehicle design.

Frame

Welded high-strength low-alloy steel frame. Box-section variable-height side-members are interconnected by cross-members. Cast elements are used in places of maximum loading.

Weight

Maximum payload capacity, kg	90000	
Unladen weight, kg	74000	
Gross weight, kg	164000	
Dump truck weight distribution on axles, %:		
	unloaded	loaded
front axle	50.9	33.0
rear axle	49.1	67.0

Refill capacities, l

Fuel tank	1105
Engine cooling system (tropicalized dump truck)	260 (380)
Engine lubrication system	140
Hydraulic system	510
Motor-in-wheel reducers	80 (40x2)
Suspension cylinders:	
front	31.4 (15.7x2)
rear	58.0 (29.0x2)

Tires

Pneumatic, tubeless tires. Open cast mine tread pattern.

Tire designation 27.00R49; 31/90-49

Tire inflation pressure as recommended by tire producer

Rim designation 19.50-49/4.0

Towing and braking performance

